

THANKS FOR PURCHASING OUR PRODUCT

# PROMIG200 LCD

Inverter MIG/MAG/MMA Semi-auto ARC Welding Machine

## Operation Manual

(Read the manual carefully before installation ,operation and maintenance)

(BE SUITABLE FOR 1x230V)





## SAFETY PRECAUTIONS

**Follow these precautions carefully. Improper use of any welder can result in injury or death.**

1. ONLY CONNECT WELDER TO A POWER SOURCE FOR WHICH IT WAS DESIGNED. The specification plate on the welder lists this information. When welding outdoors only use an extension cord intended for such use.
2. ONLY OPERATE WELDER IN DRY LOCATIONS and on cement or masonry floor. Keep area clean and uncluttered.
3. KEEP ALL COMBUSTIBLES AWAY FROM WORK SITE.
4. DO NOT WEAR CLOTHING THAT HAS BEEN CONTAMINATED with grease or oil.
5. KEEP CABLES DRY AND FREE FROM OIL AND GREASE and never coil around shoulders.
6. SECURE WORK WITH CLAMPS or other means; don't overreach when working.
7. NEVER STRIKE AN ARC ON A COMPRESSED GAS CYLINDER
8. DON'T ALLOW THE INSULATED PORTION OF THE ELECTRODE HOLDER TO TOUCH THE WELDING GROUND WHILE CURRENT IS FLOWING.
9. SHUT OFF POWER AND UNPLUG MACHINE WHEN REPAIRING OR ADJUSTING. Inspect before every use. Only use identical replacement part.
10. FOLLOW ALL MANUFACTURER'S RULES on operating switches and making adjustments.
11. ALWAYS WEAR PROTECTIVE CLOTHING when welding . This includes: long sleeved shirt(leather sleeves), protective apron without pockets, long protective pants and boots. When handling hot materials, wear asbestos gloves.
12. ALWAYS WEAR A WELDER'S HELMET WITH PROTECTIVE EYE PIECE when welding. Arcs may cause blindness. Wear a protective cap underneath the helmet.
13. WHEN WELDING OVERHEAD, BEWARE OF HOT METAL DROPPINGS. Always protect the head, hand, feet and body.
14. KEEP A FIRE EXTINGUISHER CLOSE BY AT ALL TIMES.
15. DO NOT EXCEED THE DUTY CYCLE OF THE MACHINE. The rated cycle of a welding machine is the percentage of a ten minute period that the machine can operate safely at a given output setting.
16. KEEP ALL CHILDREN AWAY FROM WORK AREA. When storing equipment, make sure it is out of reach of children.
17. GUARD AGAINST ELECTRIC SHOCK. DO not work when tired. Do not let body come in contact with grounded surfaces.

# Prolegomenon

We do very appreciated for your selecting our products.

This kind of welding power Model PROMIG200 LCD is taken foreign advanced technology to develop and manufacture the new generation inverter integrated controlling Semi-auto MIG/MAG ARC Welding machine.

It can be composed the PROMIG200 LCD MIG/MAG ARC Welding system equipped with wire feeder and welding gun .It has many characteristic such as easy Arc starting ,good Arc springiness ,adjustable arc thrusting ,low splash,good welding form ,easy welding operation, wide range and electricity save.

The MIG/MAG semi-auto Arc welding machine model PROMIG200 LCD is advanced welding machine and it can be compared with foreign products.

This operation manual can help you for the machine installation, operation and maintenance correctly and safely.Pay attention to the points as following.

- . Installation of the power cord. Be grounded correctly.
- . Don't put sundries under the welder.Otherwise it will affect the heat released.
- . Installation for the positive and negative cable of the power output.
- . Welding voltage selection
- . Welding current selection (speed of wire feeder)

---

The amendment right and the explanation right of the manual belonging to my company.We have no special notice if the manual is amended.

# 1. Main characteristic and suitable range

This kind of welding power Model PROMIG200 LCD is taken foreign advanced technology to develop and manufacture the new generation inverter integrated controlling Semi-auto MIG/MAG Arc welding machine. It makes use of the import key parts such as Siemens IGBT module of Germany, alloy magnetic core and the resume diode module of America. It has the perfect performance of high quality ,good reliability, quick speed of welding current, steady welding process, low splash and good welding form . Anyway, It becomes the welding very easy.

## 1.1 Structure of the PROMIG200 LCD MIG/MAG semi-auto Arc welding machine

### a. The name of the model

PROMIG200 LCD

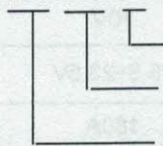

Model improvement

max welding current

Semi-auto MIG/MAG Arc welding machine

### b. Composing of the product

This product is composed by three parts as following

★ Power source(PROMIG200 LCD)

★ welding gun

## 1.2 Suitable range of the PROMIG200 LCD

★ Suitable material: low-carbon steel, stainless steel

★ Thickness of the material: low-carbon steel and stainless: more than 0.5mm

★ Suitable position: all positions

★ Suitable wire :  $\phi$  0.6, 0.8, 1.0 solid wire/flux cord wire.

## 1.3 Characteristic of PROMIG200 LCD

★ Wide output current 30-200A:  $\phi$  0.6 -----30-100A

$\phi$  0.8 -----50-180A

$\phi$  1.0 -----60-200A

★ Steady welding process, low splash, easy control, good welding form.

★ High efficiency: 180A/23V the duty cycle is 25%

120A/20V the duty cycle is 60%

90A/18.5V the duty cycle is 100%

continuous wire feed, the max speed of wire feed is 12m/min

## 2.Main technical Data :

MODEL		PROMIG200 LCD
INPUT	Voltage	1 xAC230V 50Hz
	Rated Input current	30A
	Rated Input power	6.9KVA
MMA	No-load Voltage	70V
	current Adjusting Range	20~160A
	Rated Output Current	160A
	Rated Duty Cycle	35%
MIG	No-load Voltage	70V
	Voltage Adjusting Range	15.5~23.5V
	Rated Output Current	180A
	Current Range	30~200A
	Rated Duty Cycle	25%@180A
	Suitable wire	Φ 0.6, 0.8, 0.9, 1.0
Efficiency		≥80%
Insulation class		F
Protection Class of enclosure		IP21S

## 3.Function

3.1 Adjusting function for the welding voltage and welding current

3.1.1 PROMIG200 LCD @230V supply the adjusting range at MIG/MAG as following,

Welding voltage :  $14V \pm 3V \sim 23V \pm 3V$  use the voltage adjusting knob

Welding current : 30A~200A use the current adjusting knob

3.1.2 PROMIG200 LCD supply the adjusting range at MMA as following,

Welding current : 20A~160A@230V use the welding current knob on the panel.

## 4. Indicating and warning on the PROMIG200 LCD control panel

### 4.1 Indicating and adjusting

#### FRONT PANEL

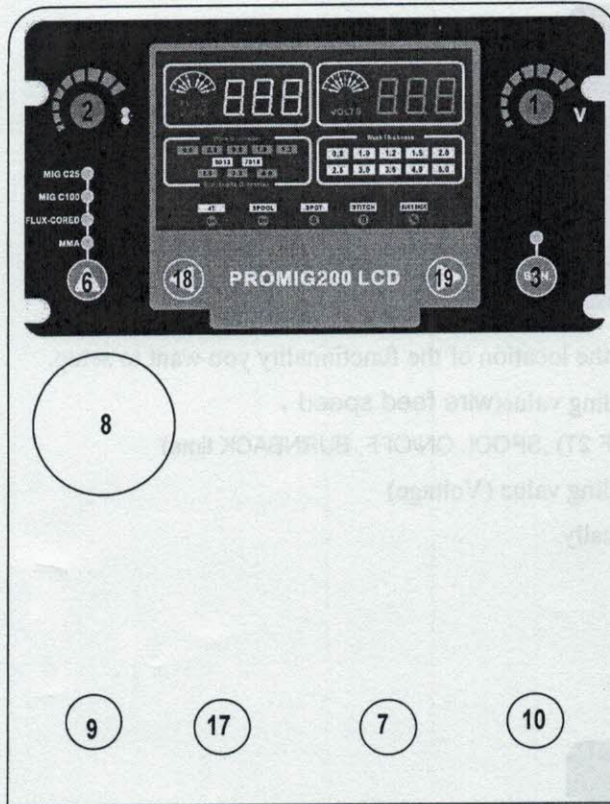

#### BACK PANEL

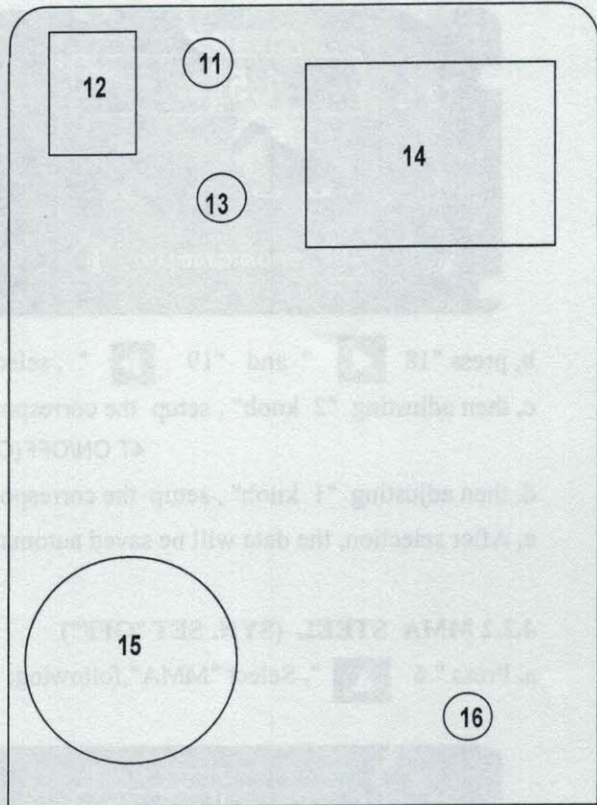

#### 4.1.1 MIG Voltage regulator

4.1.2 LEFT KNOB: wire speed / amps/burn back time, wire speed fine adjust on SYN. set when SYN. set off, All parameter adjusting@MAIN PAGE.

#### 4.1.3 SYN. switch

#### 4.1.4 Power indicating

If the indicating light is on the control circuit connects the power already.

#### 4.1.5 over heat or over current indicating

#### 4.1.6 MIG C25/MIG C100/FLUX CORE/MMA switch

4.1.7 Spool motor connector 4.1.8 MIG torch connector 4.1.9 output "-" 4.1.10 output "+"

4.1.11 incoming line of the power 4.1.12 power switch 4.1.13 Gas inlet

4.1.14 nameplate 4.1.15 FAN 4.1.16 grounding column

4.1.17 torch cable to "+" or "-" 4.1.18 wire size select switch @power set ON

4.1.19 material thickness select switch @power set ON



4.1.20 ON/OFF SYN. SET(EASY SETTING)

## 4.2 Entering Setup Menu

### 4.2.1 MIG STEEL (SYN. SET "OFF")

a, Press "6" , Select "C25 or C100 or FLUE-CORED", following:



b, press "18"  and "19" , select the location of the functionality you want to setup.

c, then adjusting "2 knob", setup the corresponding value(wire feed speed ,

4T ON/OFF(OFF 2T) ,SPOOL ON/OFF, BURNBACK time)

d, then adjusting "1 knob", setup the corresponding value (Voltage)

e, After selection, the data will be saved automatically.

### 4.2.2 MMA STEEL (SYN. SET "OFF")

a, Press "6" , Select "MMA", following:



b, then adjusting "2 knob", setup the corresponding value(AMP)

e, After selection, the data will be saved automatically.



#### 4.2.1 MIG STEEL (SYN. SET "ON")

a, Press "6" , Select "C25 or C100 or FLUE-CORED", SYN. SET "ON", following:



b, press "18" , select the wire diameter.

c, press "19" , select the workpiece thickness.

d, then fine adjusting "1 knob", setup the corresponding value (Voltage)

e, then fine adjusting "2 knob", setup the corresponding value(wire feed speed )

f, After selection, the data will be saved automatically.

#### 4.2.2 MMA STEEL (SYN. SET "ON")

a, Press "6" , Select "MMA", SYN. SET "ON", following:

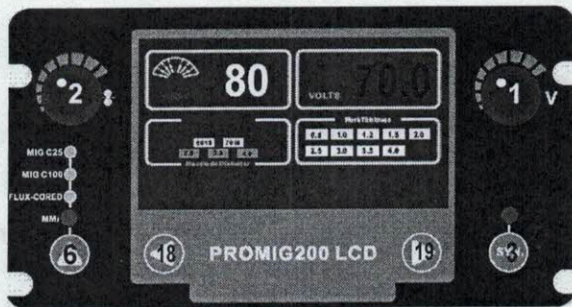

b, press "18" , select the wire diameter.

c, press "19" , select the workpiece thickness.

d, then fine adjusting "2 knob", setup the corresponding value(Amps )

e, After selection, the data will be saved automatically.

## 5.Safe and installation caution

Read the safe caution before installation and operation .It come down to the high voltage electricity,electric Arc and high temperature splash.So keep the safe regulation ,operate the machine properly,avoid the danger of electricity and high temperature arc.

- ★ Check if any damage ot out looking of the welder.
- ★ Confirm the capacity:more than 40A.
- ★ Power source is grounded,diagram 6
- ★ Prohibit the combustibile goods in the welding locale.
- ★ There is fire proof measure in the welding locale with favorable ventilated condition.
- ★ There is smoke discharge system if the welding is operated inside the house in order to keep the safety of workers.
- ★The welding operator must be professional workers.
- ★The operator must be fitted with safe accessories .Such as safe shoes,gloves,cover, welding make and welding dress etc.

## 6. Explanation of installation

### 6.1 MIG/MAG welding

- ★ Check the products according to the packing list when open the package.
- ★Grounded protection.Attached the diagram 6

The power source is 230Vac/(50~60Hz) .The yellow/green double cable is grounding cable.Be sure to connect the yellow/green double cable into the grounding connection in the welding locale .Another way is selecting the M8 bolt on the back on the machine and connect the grounding as the diagram as following.

- ★Install the welding gun on the front panel and screw the welding gun ,then lock the bolt.
- ★ Connect the gas pipe with the gas bottle according to the locale conditions. Check the air proof conditions to ensure the good airproof.

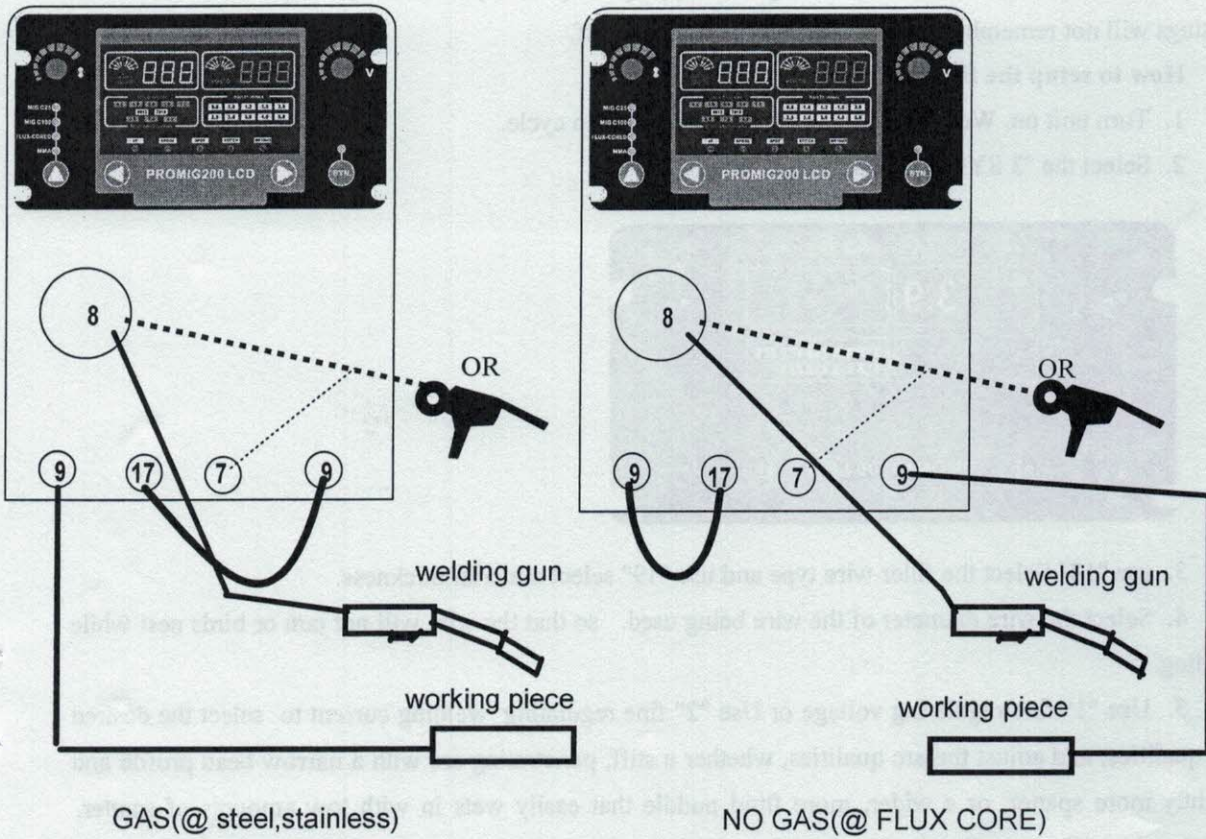
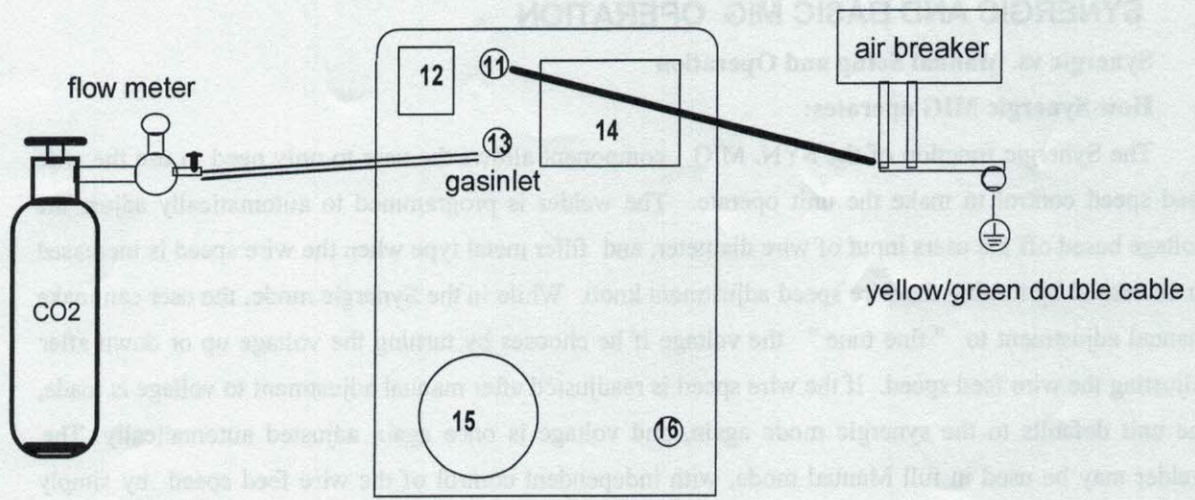

diagram 7

## SYNERGIC AND BASIC MIG OPERATION

### Synergic vs. Manual Setup and Operation

#### How Synergic MIG operates:

The Synergic function of the SYN. MIG component allows the user to only need to use the wire feed speed control to make the unit operate. The welder is programmed to automatically adjust the voltage based off the users input of wire diameter, and filler metal type when the wire speed is increased or decreased by turning the wire speed adjustment knob. While in the Synergic mode, the user can make manual adjustment to "fine tune" the voltage if he chooses by turning the voltage up or down after adjusting the wire feed speed. If the wire speed is readjusted after manual adjustment to voltage is made, the unit defaults to the synergic mode again, and voltage is once again adjusted automatically. The welder may be used in full Manual mode, with independent control of the wire feed speed by simply selecting MIG on the wire diameter selector. Settings will not be saved when the unit cycles off and back on and will default to factory settings. If stepping away briefly it is best to keep the unit on, or the settings will not remember the last settings if it is turned off.

#### How to setup the Synergic and Manual functions:

1. Turn unit on. Wait for it to go through the power up cycle.
2. Select the "3 SYN. "SETUP "ON",

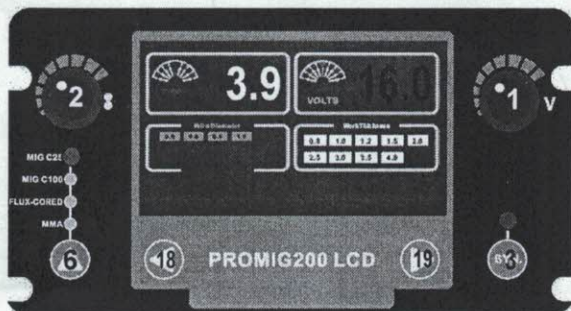

3. use "18" Select the filler wire type and use "19" select material thickness.
4. Select the wire diameter of the wire being used. so that the wire will not jam or birds nest while feeding.
5. Use "1" fine regulating voltage or Use "2" fine regulating welding current to select the desired arc qualities, and adjust the arc qualities, whether a stiff, penetrating arc with a narrow bead profile and slightly more spatter, or a wider, more fluid puddle that easily wets in with low amounts of spatter. Overhead welding usually requires a more stiff penetrating arc. Flat welding will accept a wider, more fluid puddle.

## 7. Operatings

- ★ "ON" and "OFF" indicating switch on the back panel.
- ★ Preset the welding voltage ,welding current(wire speed).
- ★ Confirm the specification of the wire feed hose
- ★ Confirm the specification of nib base .It affects the extended length of the wire .
- ★ Confirm the specification of nib. It affects the electric resistance.
- ★ Confirm the wire slot of the roller is suitable for the diameter of the wire. Different diameter of wire select different wire slot. Otherwise it affects the wire feed result.
- ★ Confirm the pressure of the roller to avoid slipping.  
If the pressure is not enough ,the wire feed is slow speed.  
If the pressure is too much ,the wire will be anamorphic.  
The wire feeder can not work properly.
- ★ Confirm the flow of the gas and air proof.

We suggest the gas flow to be "L" more than 10D(D-diameter of wire ).If the selection is not proper,it also affects the welding quality.When using the CO<sub>2</sub> gas,please confirm if the heating power works properly or not .

★ Straight the hose of welding gun as much as possible .The bending radius can not be less than 160mm.Otherwise it affects the wire feeder.

### 7.1 working process

press the switch of the gun ,the normal welding begins.Relax the switch,the arc stops.

### 7.2 Gas inspection

Press the switch of the gun before the wire roller is firmed,preset the gas flow through the meter to check if it is gas proof.Otherwise ,it affects the welding result.

### 7.3Rip into the wire

Select the specification of the wire ,materials according to the craft requirements.Firm the bolt and press the button on the front panel.The speed of ripping wire can be controlled by the welding current knob.Unload the nib if necessary and load it again after the wire is out.

## 8. working elements

Diagram for the PROMIG200 LCD working elements.Digram9

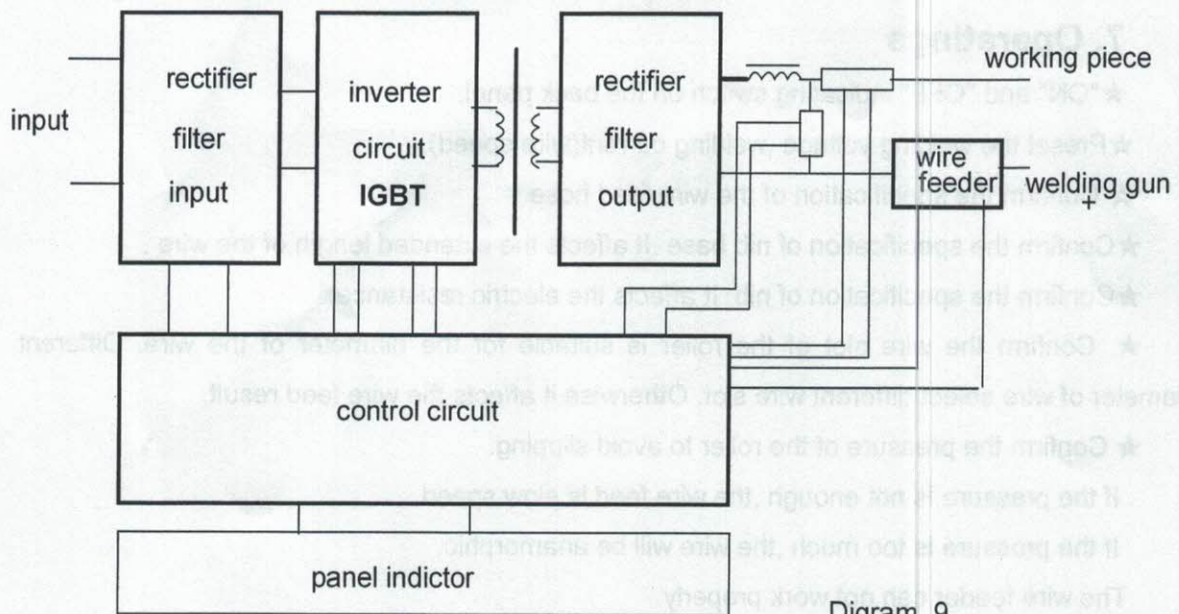

Diagram 9

Input AC 230V, rectifier and filter it into 300VDC.

Control the IGBT by PWM+PFM, inverter the 300VDC to 55KHZ AC.

High frequency transformer pass the power by insulation and voltage reducing with high efficiency.

Output the second rectifier and the second filter. Output the required welding current and voltage.

## 9. Maintenance

Check the safety measure be efficiency.

Get rid of the dust for the power source (FOR example, dry compressed air)

Before operating,, Check the "workpiece" "torch" connectors of the power panel if they are relaxed

.Check the connection between the grounding cable and plug if they are relaxed, (If relaxed, the serious heating will damage the quick connectors)

.Check the fan if it works regularly. charge it if it is trouble.

Check the insulation and breakage of the input power cord

.Change it in time to ensure the safety.

check if there is any noisy for the wire feed motor.

Check the abrasion of the wire feed hose. Get rid of the dust inside of the hose. (!~2times / 40kg wire)

.Get rid of the splash inside the nib regularly to ensure the guaranteed result by the gas

blow.

Check the abrasion of the nib. Change it in time. (suggest 5~10 pieces nibs/40kg wire).

## 10. Troubles and Remedy

Troubles and remedy and remedy are as the form 10 as following

Troubles	Cause	Remedy
1. Fan not works properly	1. the fan line lose 2. Fan breakage	1. Connect the line 2. Change the fan
2. No indicating on the front panel	1. the power line lose 2. Indicating light broken	1. Check the power, Connect the line 2. Change it( $\phi$ 8)
3. Over heating light on (use mig)	1. aeration is not good 2. The temperature is too high 3. over-load use 4. Thermostat broken 5. Control plate broken	1. get rid of the bar 0.5m around 2. Reduce the temperature 3. Reduce the use loading 4. Change the thermostat(JUC-OFF) 5. Check and change the control plate
5. Wire feeder not work ( welding current not adjustable)	1. Potentiometer line fall down or Potentiometer broken 2. the wire blocked 3. the drive circuit broken 4. no output 5. other reasons	1. Connect the lines or Change it 2. Check the gun 3. Change the control panel 4. Contact with the manufacturer 5. Contact with the manufacturer
6. Welding Voltage not adjustable	1. Potentiometer line fall down 2. Potentiometer broken 3. The circuit broken	1. Connect the lines 2. Change it 3. Change the control pcb
7. Welding stops, and warning light is on	Self-protection has engaged 1. Display "E01" 2. Display "E02"	1. over-temperature, 2. over-current,

## 11. Transportation, storage and environment conditions

★ The package (Wooden cases or cartons) of the manufacturer is suitable for air, sea, railway and highway (three class more) transportation.

★ Pay attention to the indication on the package during the transportation.

★ the environment conditions

A Temperature range	operating	0°C ~ 40°C
	transportation	-25°C ~ +55°C
B The air humidity	40°C	50%RH
	20°C	90%RH
C The dust, acid and causticity gas in the environment must be lower than the normal level		

(The welding process produced not included)

D Rain proof when it is used outside.

## 12. Quality Guaranteed

If you have any problem of the quality, please contact us in time. We generally have one year quality guarantee on condition that you operate or transport the machine properly according to the operation manual.



<b>WARNING</b>	<ul style="list-style-type: none"> <li>● Do not touch electrically live parts or electrode with skin or wet clothing.</li> <li>● Insulate yourself from work and ground.</li> </ul>	<ul style="list-style-type: none"> <li>● Keep flammable materials away.</li> </ul>	<ul style="list-style-type: none"> <li>● Wear eye, ear and body protection.</li> </ul>
Spanish <b>AVISO DE PRECAUCION</b>	<ul style="list-style-type: none"> <li>● No toque las partes o los electrodos bajo carga con la piel o ropa mojada.</li> <li>● Aíslese del trabajo y de la tierra.</li> </ul>	<ul style="list-style-type: none"> <li>● Mantenga el material combustible fuera del área de trabajo.</li> </ul>	<ul style="list-style-type: none"> <li>● Protéjase los ojos, los oídos y el cuerpo.</li> </ul>
French <b>ATTENTION</b>	<ul style="list-style-type: none"> <li>● Ne laissez ni la peau ni des vêtements mouillés entrer en contact avec des pièces sous tension.</li> <li>● Isolez-vous du travail et de la terre.</li> </ul>	<ul style="list-style-type: none"> <li>● Gardez à l'écart de tout matériel inflammable.</li> </ul>	<ul style="list-style-type: none"> <li>● Protégez vos yeux, vos oreilles et votre corps.</li> </ul>
German <b>WARNUNG</b>	<ul style="list-style-type: none"> <li>● Berühren Sie keine stromführenden Teile oder Elektroden mit Ihrem Körper oder feuchter Kleidung!</li> <li>● Isolieren Sie sich von den Elektroden und dem Erdboden!</li> </ul>	<ul style="list-style-type: none"> <li>● Entfernen Sie brennbares Material!</li> </ul>	<ul style="list-style-type: none"> <li>● Tragen Sie Augen-, Ohren- und Körperschutz!</li> </ul>
Portuguese <b>ATENÇÃO</b>	<ul style="list-style-type: none"> <li>● Não toque partes elétricas e electrodos com a pele ou roupa molhada.</li> <li>● Isole-se da peça e terra.</li> </ul>	<ul style="list-style-type: none"> <li>● Mantenha inflamáveis bem guardados.</li> </ul>	<ul style="list-style-type: none"> <li>● Use proteção para a vista, ouvido e corpo.</li> </ul>
Japanese <b>注意事項</b>	<ul style="list-style-type: none"> <li>● 通電中の電気部品、又は溶材にヒブやぬれた布で触れないこと。</li> <li>● 施工物やアースから身体が絶縁されている様にして下さい。</li> </ul>	<ul style="list-style-type: none"> <li>● 燃えやすいものの側での溶接作業は絶対にはなりません。</li> </ul>	<ul style="list-style-type: none"> <li>● 目、耳及び身体に保護具をして下さい。</li> </ul>
Chinese <b>警告</b>	<ul style="list-style-type: none"> <li>● 皮肤或湿衣物切勿接触带电部件及焊条。</li> <li>● 使你自已与地面和工件绝缘。</li> </ul>	<ul style="list-style-type: none"> <li>● 把一切易燃物品移離工作場所。</li> </ul>	<ul style="list-style-type: none"> <li>● 佩戴眼、耳及身體勞動保護用具。</li> </ul>
Korean <b>위험</b>	<ul style="list-style-type: none"> <li>● 전도체나 용접봉을 젖은 헝겊 또는 피부로 절대 접촉하지 마십시오.</li> <li>● 모재와 접지를 접촉하지 마십시오.</li> </ul>	<ul style="list-style-type: none"> <li>● 인화성 물질을 접근시키지 마십시오.</li> </ul>	<ul style="list-style-type: none"> <li>● 눈, 귀와 몸에 보호장구를 착용하십시오.</li> </ul>
Arabic <b>تحذير</b>	<ul style="list-style-type: none"> <li>● لا تلمس الأجزاء التي يسري فيها التيار الكهربائي أو الألكترود بجلد الجسم أو بالملابس المبللة بالماء.</li> <li>● ضع عازلا على جسمك خلال العمل.</li> </ul>	<ul style="list-style-type: none"> <li>● ضع المواد القابلة للاشتعال في مكان بعيد.</li> </ul>	<ul style="list-style-type: none"> <li>● ضع أدوات وملابس واقية على عينيك وأذنيك وجسمك.</li> </ul>

READ AND UNDERSTAND THE MANUFACTURER'S INSTRUCTION FOR THIS EQUIPMENT AND THE CONSUMABLES TO BE USED AND FOLLOW YOUR EMPLOYER'S SAFETY PRACTICES.

SE RECOMIENDA LEER Y ENTENDER LAS INSTRUCCIONES DEL FABRICANTE PARA EL USO DE ESTE EQUIPO Y LOS CONSUMIBLES QUE VA A UTILIZAR, SIGA LAS MEDIDAS DE SEGURIDAD DE SU SUPERVISOR.

LISEZ ET COMPRENEZ LES INSTRUCTIONS DU FABRICANT EN CE QUI REGARDE CET EQUIPMENT ET LES PRODUITS A ETRE EMPLOYES ET SUIVEZ LES PROCEDURES DE SECURITE DE VOTRE EMPLOYEUR.

LESEN SIE UND BEFOLGEN SIE DIE BETRIEBSANLEITUNG DER ANLAGE UND DEN ELEKTRODENEINSATZ DES HERSTELLERS. DIE UNFALLVERHÜTUNGSVORSCHRIFTEN DES ARBEITGEBERS SIND EBENFALLS ZU BEACHTEN.

			
<ul style="list-style-type: none"> <li>● Keep your head out of fumes.</li> <li>● Use ventilation or exhaust to remove fumes from breathing zone.</li> </ul>	<ul style="list-style-type: none"> <li>● Turn power off before servicing.</li> </ul>	<ul style="list-style-type: none"> <li>● Do not operate with panel open or guards off.</li> </ul>	<b>WARNING</b>
<ul style="list-style-type: none"> <li>● Los humos fuera de la zona de respiración.</li> <li>● Mantenga la cabeza fuera de los humos. Utilice ventilación o aspiración para gases.</li> </ul>	<ul style="list-style-type: none"> <li>● Desconectar el cable de alimentación de poder de la máquina antes de iniciar cualquier servicio.</li> </ul>	<ul style="list-style-type: none"> <li>● No operar con panel abierto o guardas quitadas.</li> </ul>	Spanish <b>AVISO DE PRECAUCION</b>
<ul style="list-style-type: none"> <li>● Gardez la tête à l'écart des fumées.</li> <li>● Utilisez un ventilateur ou un aspirateur pour ôter les fumées des zones de travail.</li> </ul>	<ul style="list-style-type: none"> <li>● Débranchez le courant avant l'entretien.</li> </ul>	<ul style="list-style-type: none"> <li>● N'opérez pas avec les panneaux ouverts ou avec les dispositifs de protection enlevés.</li> </ul>	French <b>ATTENTION</b>
<ul style="list-style-type: none"> <li>● Vermeiden Sie das Einatmen von Schweißrauch!</li> <li>● Sorgen Sie für gute Be- und Entlüftung des Arbeitsplatzes!</li> </ul>	<ul style="list-style-type: none"> <li>● Strom vor Wartungsarbeiten abschalten! (Netzstrom völlig öffnen; Maschine anhalten!)</li> </ul>	<ul style="list-style-type: none"> <li>● Anlage nie ohne Schutzgehäuse oder Innenschutzverkleidung in Betrieb setzen!</li> </ul>	German <b>WARNUNG</b>
<ul style="list-style-type: none"> <li>● Mantenha seu rosto da fumaça.</li> <li>● Use ventilação e exaustão para remover fumo da zona respiratória.</li> </ul>	<ul style="list-style-type: none"> <li>● Não opere com as tampas removidas.</li> <li>● Desligue a corrente antes de fazer serviço.</li> <li>● Não toque as partes elétricas nuas.</li> </ul>	<ul style="list-style-type: none"> <li>● Mantenha-se afastado das partes moventes.</li> <li>● Não opere com os painéis abertos ou guardas removidas.</li> </ul>	Portuguese <b>ATENÇÃO</b>
<ul style="list-style-type: none"> <li>● ヒュームから頭を離すようにして下さい。</li> <li>● 換気や排煙に十分留意して下さい。</li> </ul>	<ul style="list-style-type: none"> <li>● メンテナンス・サービスに取りかかる際には、まず電源スイッチを必ず切って下さい。</li> </ul>	<ul style="list-style-type: none"> <li>● パネルやカバーを取り外したまま機械操作をしないで下さい。</li> </ul>	Japanese <b>注意事項</b>
<ul style="list-style-type: none"> <li>● 頭部遠離煙霧。</li> <li>● 在呼吸區使用通風或排風器除煙。</li> </ul>	<ul style="list-style-type: none"> <li>● 維修前切斷電源。</li> </ul>	<ul style="list-style-type: none"> <li>● 儀表板打開或沒有安全罩時不準作業。</li> </ul>	Chinese <b>警告</b>
<ul style="list-style-type: none"> <li>● 얼굴로부터 용접가스를 멀리하십시오.</li> <li>● 호흡지역으로부터 용접가스를 제거하기 위해 가스제거기나 통풍기를 사용하십시오.</li> </ul>	<ul style="list-style-type: none"> <li>● 보수전에 전원을 차단하십시오.</li> </ul>	<ul style="list-style-type: none"> <li>● 패널이 열린 상태로 작동치 마십시오.</li> </ul>	Korean <b>위험</b>
<ul style="list-style-type: none"> <li>● أبعد رأسك بعيداً عن الدخان.</li> <li>● استعمل التهوية أو جهاز ضغط الدخان للخارج لكي تبعد الدخان عن المنطقة التي تتنفس فيها.</li> </ul>	<ul style="list-style-type: none"> <li>● افصل التيار الكهربائي قبل القيام بأية صيانة.</li> </ul>	<ul style="list-style-type: none"> <li>● لا تشغيل هذا الجهاز اذا كانت الاغطية الحديدية الواقية ليست عليه.</li> </ul>	Arabic <b>تحذير</b>

**LEIA E COMPREENDA AS INSTRUÇÕES DO FABRICANTE PARA ESTE EQUIPAMENTO E AS PARTES DE USO, E SIGA AS PRÁTICAS DE SEGURANÇA DO EMPREGADOR.**

使う機械や溶材のメーカーの指示書をよく読み、まず理解して下さい。そして貴社の安全規定に従って下さい。

請詳細閱讀並理解製造廠提供的說明以及應該使用的銀焊材料，並請遵守貴方的有關勞動保護規定。

이 제품에 동봉된 작업지침서를 숙지하시고 귀사의 작업자 안전수칙을 준수하시기 바랍니다.

اقرأ بتمعن وافهم تعليمات المصنع المنتج لهذه المعدات والمواد قبل استعمالها واتبع تعليمات الوقاية لصاحب العمل.

**13.ACCESSORIES:SEE PACKING LIST,PLEASE**

**PACKING LIST**



PROMIG200 LCD Welding machine	1		[PACKING 1]
cable+Ground pliers	1		[PACKING 1]
MIG welding torch	1		[PACKING 1]
Welding holder	1		[PACKING 1]
Spool welding torch(QLBT 8m)	1	optional accessory	
Operation instructions	1		[PACKING 1]
Certificate of quality	1		[PACKING 1]

No. \_\_\_\_\_

**Certificate of quality**

Name of product:MIG/MAG /MMA Semi-auto ARC Welding Machine

Type of product: : PROMIG200 LCD

Packing No: 462114272

Test results of this welder fulfils \_\_\_\_\_

\_\_\_\_\_technical requirements and its release

from the works is granted.

Inspector INSP.1 Date 02 11 2022



TO ACCESSORISE: SEE PACKING LIST, PLEASE

PACKING LIST

\*\*\*\*\*

PR. WIGSON, CO			
Welding machine			PACKING 1
Cap+Ground gear	1		PACKING 1
MIG welding torch	1		PACKING 1
Welding holder	1		PACKING 1
Special welding torch (LBT 5m)	1	optional accessory	
Operation instructions	1		PACKING 1
Certificate of quality	1		PACKING 1

No

Certificate of quality

Name of product: MIG/MAG MMA Semiauto ARC Welding Machine

482114272

Packing No:

Test results of this welder/turbine

Technical requirements and its release

from the works is granted.

Inspector: Insp. Date: 02 11 2022



0.12/11

0.12/11