

THANKS FOR PURCHASING PRODUCT



ProArc205STL

DC INVERTER
MMA/DC
WELDING MACHINE

ASSEMBLY AND OPERATING INSTRUCTIONS

(BE SUITABLE FOR 220~240V)



SAFETY PRECAUTIONS

Follow these precautions carefully. Improper use of any welder can result in injury or death.

1. ONLY CONNECT WELDER TO A POWER SOURCE FOR WHICH IT WAS DESIGNED. The specification plate on the welder lists this information. When welding outdoors only use an extension cord intended for such use.
2. ONLY OPERATE WELDER IN DRY LOCATIONS and on cement or masonry floor. Keep area clean and uncluttered.
3. KEEP ALL COMBUSTIBLES AWAY FROM WORK SITE.
4. DO NOT WEAR CLOTHING THAT HAS BEEN CONTAMINATED with grease or oil.
5. KEEP CABLES DRY AND FREE FROM OIL AND GREASE and never coil around shoulders.
6. SECURE WORK WITH CLAMPS or other means; don't overreach when working.
7. NEVER STRIKE AN ARC ON A COMPRESSED GAS CYLINDER
8. DON'T ALLOW THE INSULATED PORTION OF THE ELECTRODE HOLDER TO TOUCH THE WELDING GROUND WHILE CURRENT IS FLOWING.
9. SHUT OFF POWER AND UNPLUG MACHINE WHEN REPAIRING OR ADJUSTING. Inspect before every use. Only use identical replacement parts.
10. FOLLOW ALL MANUFACTURER'S RULES on operating switches and making adjustments.
11. ALWAYS WEAR PROTECTIVE CLOTHING when welding . This includes: long sleeved shirt(leather sleeves), protective apron without pockets, long protective pants and boots. When handling hot materials, wear asbestos gloves.
12. ALWAYS WEAR A WELDER'S HELMET WITH PROTECTIVE EYE PIECE when welding. Arcs may cause blindness. Wear a protective cap underneath the helmet.
13. WHEN WELDING OVERHEAD, BEWARE OF HOT METAL DROPPINGS. Always protect the head, hand, feet and body.
14. KEEP A FIRE EXTINGUISHER CLOSE BY AT ALL TIMES.
15. DO NOT EXCEED THE DUTY CYCLE OF THE MACHINE. The rated cycle of a welding machine is the percentage of a ten minute period that the machine can operate safely at a given output setting.
16. KEEP ALL CHILDREN AWAY FROM WORK AREA. When storing equipment, make sure it is out of reach of children.
17. GUARD AGAINST ELECTRIC SHOCK. DO not work when tired. Do not let body come in contact with grounded surfaces.

1. MAIN USAGE AND THE RANGE OF USAGE(APPLICATIONS):

ProArc205STL inverse arc welder produced with international advanced technology is a new variety of welding machine using IGBT. It has performance and high efficiency that the traditional welder can not be compared with. The welding current is infinitely and independently adjustable. All ferrous metal, copper and stainless steel material can be omnibearing welding in all position. The welding current is stable. The welding seam is nice. few spatters and low noise occurs during welding. The welder has outstanding feature of minimum current. The minimum current can be up to 20A. Protection measures of the welder are perfect. The welder is reliable, light in weight and easy to use. It is particularly suitable for enterprise of plant and mine, build, decoration and maintenance sectors.

2. OPERATING CONDITION AND WORK SURROUNDING

1. Operating condition:

Voltage of power source: single phase, AC 220/230/240V \pm 10%

Frequency: 50/60Hz

Reliable grounding protection

2. Work surrounding

(1) relative humidity: \leq 90% (average monthly temperature \leq 20°C)

(2) ambient temperature: -10°C - 40°C

(3) The welding site should have no harmful gas, chemicals, molds and inflammable matter, explosive and corrosive medium, no big vibration and bump to the welder.

(4) Avoiding rain water. Operating in rain is not allowed.

3. MAIN TECHNICAL SPECIFICATIONS

Model		ProArc205STL
Power Supply Voltage		AC 220/230/240 V (Single phase), 50/60Hz
MMA	No-load Voltage	74V
	Welding Cur. Adjusting Range	20-200A
	Rated Output Current	200A
	Rated Duty Cycle	35%
Mass		5.8kg
Protection Class of enclosure		IP21S
outline Dimensions (mm)		300*180*230

4. DESCRIPTION OF THE ERECTION

- Before welding, the operator should read the operation instructions and uses the welder correctly according to the process specification.
- Checking the welder appearance for deformation and damage.
- For the safety of the equipment and the persons, the customer must correctly make grounding

or protecting according to the power supply system: using 4 mm² lead to connect the protection grounding of the welder.

d. Welding operation should be carried out in dry and good ventilating area. The surrounding objects should be not less than 0.5m away from the welder.

e. Checking the welder output connector for tightness.

f. The welder can not be moved or the cover can not be opened during the power is on and welding operation is carried out.

g. The welder should be cared, used and managed by specialized person.

h. Confirming that the power source is single phase and 220/230/240V ± 10%. Current of the distribution board: 5KVA.

It can not be connected with 380V power absolutely.

5. SKETCH OF THE PANEL FUNCTION

FRONT PANEL

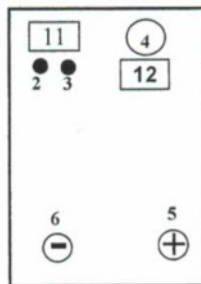

BACK PANEL

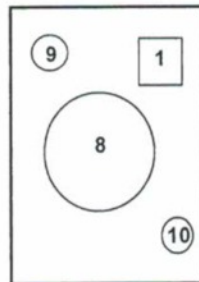

- | | | |
|----------------------------|-----------------------------------|-------------------------------|
| 1. power switch | 2. indicating light of power | 3. warning indicating light |
| 4. current regulator | 5. output "+" | 6. output "-" |
| 7. data plate | 8. fan | 9. incoming line of the power |
| 10. safety earthing column | 11. indication of welding current | 12. MMA/TIG switch |

6. METHOD OF THE OPERATION

6-1. hand welding with electrode(MMA)

Put switch "12" (MMA/TIG switch) onto the position "MMA".

Selecting empiric formula: $I=40*d$, d is dia. of the electrode.

6-2. Notice positive and negative connection during welding.

A positive connection

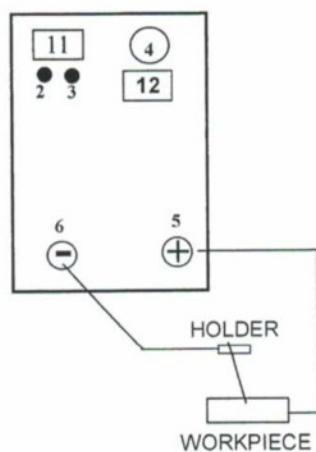

B negative connection

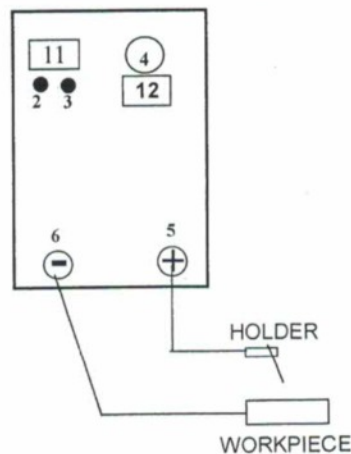

6-3.DC ARGON ARC WELDING (LIFT TIG)

- ①.Put switch "12" (MMA/TIG switch) onto the position "TIG".
- ②.Connecting gas inlet pipe of the welding torch to argon bottle.
- ③. Testing gas: open the argon bottle switch and switch on the flow meter, select suitable argon flow.
- ④.Regulating the current knob "4" . Selecting suitable welding current according to thickness of the workpiece to be welded.
- ⑤.When the welding operation is finished, turn off argon bottle switch and cut off input power of the welder.

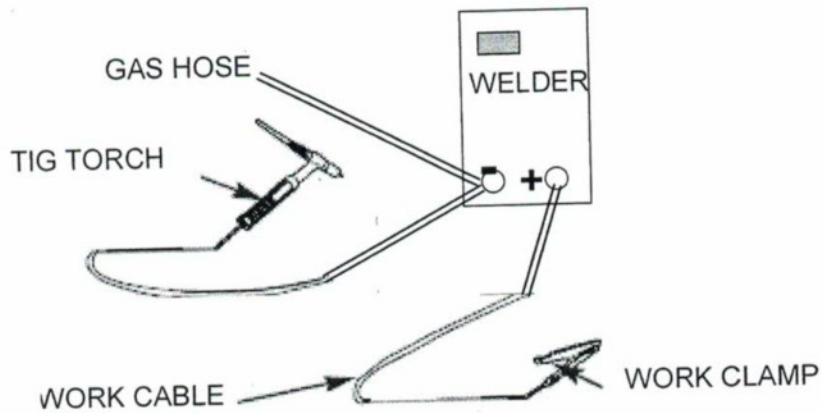

7. SYSTEMATIC BLOCK DIAGRAM

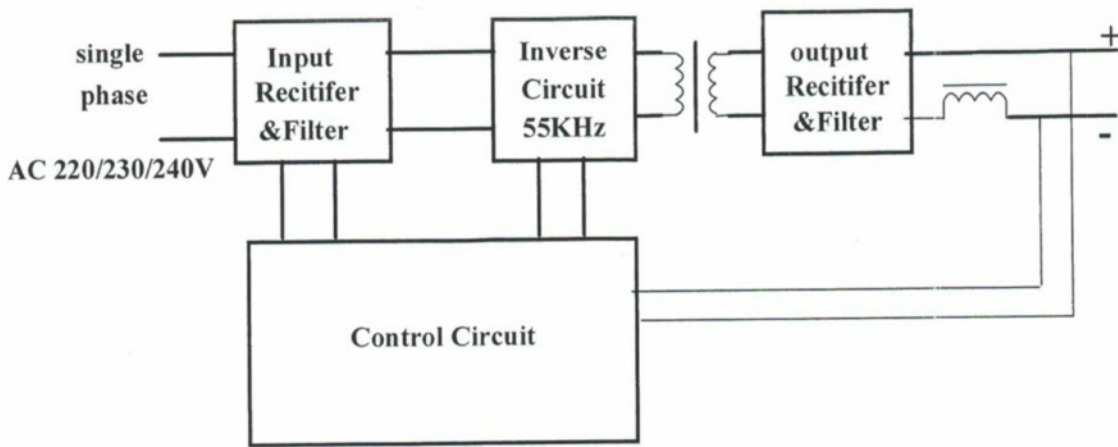

8. TROUBLES AND PROBLEM SOLVING

trouble	causes	problem solving
power lamp is not lit	<ol style="list-style-type: none"> 1. No electricity at input 2. switch of welder power fails 	<ol style="list-style-type: none"> 1. Checking incoming line 2. Replace the switch
Fan not rotating	<ol style="list-style-type: none"> 1. Fan power line is off 2. Enclosure blocks the fan due to deformation 3. The fan fails 	<ol style="list-style-type: none"> 1. Reconnect the line 2. reform the enclosure 3. replace
Warning lamp lights No output of welder	<ol style="list-style-type: none"> 1. Overheat protection 2. Short interval of welder switching on and off 3. Welder fails 	<ol style="list-style-type: none"> 1. Welding after cools 2. Extending on-off time 3. Maintenance in manufacturer or service center
Output current decreased	<ol style="list-style-type: none"> 1. Input voltage is low 2. Input line is too thin 	<ol style="list-style-type: none"> 1. AC voltage stabilizer(over 5KVA) 2. Power line is thickened
Current can not be regulated	<ol style="list-style-type: none"> 1. Connecting line of the potentiometer is off 2. Potentiometer for current regulation fails 	<ol style="list-style-type: none"> 1. Reconnecting the line 2. Replace potentiometer

			
WARNING	<ul style="list-style-type: none"> Do not touch electrically live parts or electrode with skin or wet clothing. Insulate yourself from work and ground. 	<ul style="list-style-type: none"> Keep flammable materials away. 	<ul style="list-style-type: none"> Wear eye, ear and body protection.
Spanish AVISO DE PRECAUCION	<ul style="list-style-type: none"> No toque las partes o los electrodos bajo carga con la piel o ropa mojada. Aislese del trabajo y de la tierra. 	<ul style="list-style-type: none"> Mantenga el material combustible fuera del área de trabajo. 	<ul style="list-style-type: none"> Protéjase los ojos, los oídos y el cuerpo.
French ATTENTION	<ul style="list-style-type: none"> Ne laissez ni la peau ni des vêtements mouillés entrer en contact avec des pièces sous tension. Isolez-vous du travail et de la terre. 	<ul style="list-style-type: none"> Gardez à l'écart de tout matériel inflammable. 	<ul style="list-style-type: none"> Protégez vos yeux, vos oreilles et votre corps.
German WARNUNG	<ul style="list-style-type: none"> Berühren Sie keine stromführenden Teile oder Elektroden mit Ihrem Körper oder feuchter Kleidung! Isolieren Sie sich von den Elektroden und dem Erdboden! 	<ul style="list-style-type: none"> Entfernen Sie brennbares Material! 	<ul style="list-style-type: none"> Tragen Sie Augen-, Ohren- und Körperschutz!
Portuguese ATENÇÃO	<ul style="list-style-type: none"> Não toque partes elétricas e electrodos com a pele ou roupa molhada. Isolare-se da peça e terra. 	<ul style="list-style-type: none"> Mantenha inflamáveis bem guardados. 	<ul style="list-style-type: none"> Use proteção para a vista, ouvido e corpo.
Japanese 注意事項	<ul style="list-style-type: none"> 通電中の電気部品、又は溶材にヒフやぬれた布で触れないこと。 麻工物やアースから身体が絶縁されている様にして下さい。 	<ul style="list-style-type: none"> 燃えやすいものの側での溶接作業は絶対にしてはなりません。 	<ul style="list-style-type: none"> 目、耳及び身体に保護具をして下さい。
Chinese 警告	<ul style="list-style-type: none"> 皮肤或湿衣物切勿接触带电部件及焊条。 使你自已与地面和工件绝缘。 	<ul style="list-style-type: none"> 把一切易燃物品移离工作场所。 	<ul style="list-style-type: none"> 佩戴眼、耳及身体劳动保护用具。
Korean 위험	<ul style="list-style-type: none"> 전도체나 용접봉을 젖은 환경 또는 피부로 절대 접촉치 마십시오. 모재와 접지를 접촉치 마십시오. 	<ul style="list-style-type: none"> 인화성 물질을 접근 시키지 마십시오. 	<ul style="list-style-type: none"> 눈, 귀와 몸에 보호장구를 착용하십시오.
Arabic تحذير	<ul style="list-style-type: none"> لا تلمس الأجزاء التي يسري فيها التيار الكهربائي أو الأقطاب بجسدك أو بالملابس المبللة بالماء. ضع عازلاً على جسمك خلال العمل. 	<ul style="list-style-type: none"> ضع المواد القابلة للاشتعال في مكان بعيد. 	<ul style="list-style-type: none"> ضع أدوات وملابس واقية على عينيك وأذنيك وجسمك.

READ AND UNDERSTAND THE MANUFACTURER'S INSTRUCTION FOR THIS EQUIPMENT AND THE CONSUMABLES TO BE USED AND FOLLOW YOUR EMPLOYER'S SAFETY PRACTICES.

SE RECOMIENDA LEER Y ENTENDER LAS INSTRUCCIONES DEL FABRICANTE PARA EL USO DE ESTE EQUIPO Y LOS CONSUMIBLES QUE VA A UTILIZAR, SIGA LAS MEDIDAS DE SEGURIDAD DE SU SUPERVISOR.

LISEZ ET COMPRENEZ LES INSTRUCTIONS DU FABRICANT EN CE QUI REGARDE CET EQUIPMENT ET LES PRODUITS A ETRE EMPLOYES ET SUIVEZ LES PROCEDURES DE SECURITE DE VOTRE EMPLOYEUR.

LESEN SIE UND BEFOLGEN SIE DIE BETRIEBSANLEITUNG DER ANLAGE UND DEN ELEKTRODENEINSATZ DES HERSTELLERS. DIE UNFALLVERHÜTUNGSVORSCHRIFTEN DES ARBEITGEBERS SIND EBENFALLS ZU BEACHTEN.

			
<ul style="list-style-type: none"> ● Keep your head out of fumes. ● Use ventilation or exhaust to remove fumes from breathing zone. 	<ul style="list-style-type: none"> ● Turn power off before servicing. 	<ul style="list-style-type: none"> ● Do not operate with panel open or guards off. 	WARNING
<ul style="list-style-type: none"> ● Los humos fuera de la zona de respiración. ● Mantenga la cabeza fuera de los humos. Utilice ventilación o aspiración para gases. 	<ul style="list-style-type: none"> ● Desconectar el cable de alimentación de poder de la máquina antes de iniciar cualquier servicio. 	<ul style="list-style-type: none"> ● No operar con panel abierto o guardas quitadas. 	Spanish AVISO DE PRECAUCION
<ul style="list-style-type: none"> ● Gardez la tête à l'écart des fumées. ● Utilisez un ventilateur ou un aspirateur pour ôter les fumées des zones de travail. 	<ul style="list-style-type: none"> ● Débranchez le courant avant l'entretien. 	<ul style="list-style-type: none"> ● N'opérez pas avec les panneaux ouverts ou avec les dispositifs de protection enlevés. 	French ATTENTION
<ul style="list-style-type: none"> ● Vermeiden Sie das Einatmen von Schweißrauch! ● Sorgen Sie für gute Be- und Entlüftung des Arbeitsplatzes! 	<ul style="list-style-type: none"> ● Strom vor Wartungsarbeiten abschalten! (Netzstrom völlig öffnen; Maschine anhalten!) 	<ul style="list-style-type: none"> ● Anlage nie ohne Schutzgehäuse oder Innenschutzverkleidung in Betrieb setzen! 	German WARNUNG
<ul style="list-style-type: none"> ● Mantenha seu rosto da fumaça. ● Use ventilação e exaustão para remover fumo da zona respiratória. 	<ul style="list-style-type: none"> ● Não opere com as tampas removidas. ● Desligue a corrente antes de fazer serviço. ● Não toque as partes elétricas nuas. 	<ul style="list-style-type: none"> ● Mantenha-se afastado das partes moventes. ● Não opere com os painéis abertos ou guardas removidas. 	Portuguese ATENÇÃO
<ul style="list-style-type: none"> ● ヒュームから頭を離すようにして下さい。 ● 換気や排煙に十分留意して下さい。 	<ul style="list-style-type: none"> ● メンテナンス・サービスに取りかかる際には、まず電源スイッチを必ず切して下さい。 	<ul style="list-style-type: none"> ● パネルやカバーを取り外したまま機械操作をしないで下さい。 	Japanese 注意事項
<ul style="list-style-type: none"> ● 頭部遠離煙霧。 ● 在呼吸區使用通風或排風器除煙。 	<ul style="list-style-type: none"> ● 維修前切斷電源。 	<ul style="list-style-type: none"> ● 儀表板打開或沒有安全罩時不準作業。 	Chinese 警告
<ul style="list-style-type: none"> ● 얼굴로부터 용접가스를 멀리하십시오. ● 호흡지역으로부터 용접가스를 제거하기 위해 가스제거기나 통풍기를 사용하십시오. 	<ul style="list-style-type: none"> ● 보수전에 전원을 차단하십시오. 	<ul style="list-style-type: none"> ● 패널이 열린 상태로 작동치 마십시오. 	Korean 위험
<ul style="list-style-type: none"> ● بعد رأسك بعيداً عن الدخان. ● استعمل التهوية أو جهاز ضغط الدخان للخارج لكي تبعد الدخان عن المنطقة التي تتنفس فيها. 	<ul style="list-style-type: none"> ● أقطع التيار الكهربائي قبل القيام بأية صيانة. 	<ul style="list-style-type: none"> ● لا تشغيل هذا الجهاز إذا كانت الإغطية للحديدية الواقية ليست عليه. 	Arabic تحذير

LEIA E COMPREENDA AS INSTRUÇÕES DO FABRICANTE PARA ESTE EQUIPAMENTO E AS PARTES DE USO, E SIGA AS PRÁTICAS DE SEGURANÇA DO EMPREGADOR.

使う機械や溶材のメーカーの指示書をよく読み、まず理解して下さい。そして貴社の安全規定に従って下さい。

請詳細閱讀並理解製造廠提供的說明以及應該使用的銀焊材料，並請遵守貴方的有關勞動保護規定。

이 제품에 동봉된 작업지침서를 숙지하시고 귀사의 작업자 안전수칙을 준수하시기 바랍니다.

اقرأ بتمعن وافهم تعليمات المصنع المنتج لهذه المعدات والمواد قبل استعمالها واتبع تعليمات الوقاية لصاحب العمل.

